



Trussbilt

Metal Security Ceiling Systems



SecureDek®

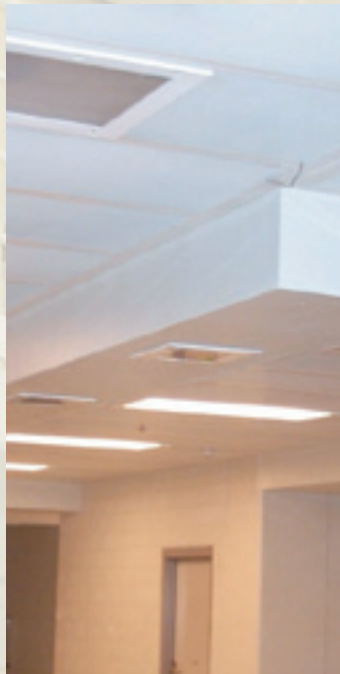

BarrierDek®



TrussDek®

Leading innovator of security products for over 85 years

Trussbilt Acoustical Metal Security Ceiling Systems

Trussbilt's Acoustical Metal Security Ceiling Systems meet the full range of security ceiling requirements, from supervised areas of minimum and medium security facilities through in-cell use in maximum security applications. And, they address the growing need to control noise in the detention setting, which creates not only a poor living environment for inmates, but also a stressful and unsafe working environment for correctional officers.

In addition to absorbing sound, Trussbilt ceilings conceal and protect plumbing, electrical and HVAC facilities. And, their unique snap-in secure lock system means they are twice as fast to install as screwed-in metal ceilings, lowering construction costs. Because Trussbilt ceiling systems are all steel, maintenance and replacement costs are dramatically reduced over the life of the building. Their life cycle costs are the lowest in the industry.

Trussbilt manufactures all access panels to ensure seamless integration with other trades. And, Trussbilt's ceiling systems can be used with their unique TrussWall® product for a single source, integrated security package that allows you to realize even more savings on your project, both at time of construction and over the life cycle of the facility.

"Our field installation crews have offered nothing but praise and high-marks for the ease of installation and uniformity of your product. This of course leads to cost savings in labor while providing opportunity to improve on construction schedules. In addition, the owners and end users of these facilities have all been impressed with the clean lines and unique detail offered in the finished product."

*G. Lee Cummings, Project Manager
Norment Security Group, Inc.*

SecureDek®
Metal Pan
Ceiling

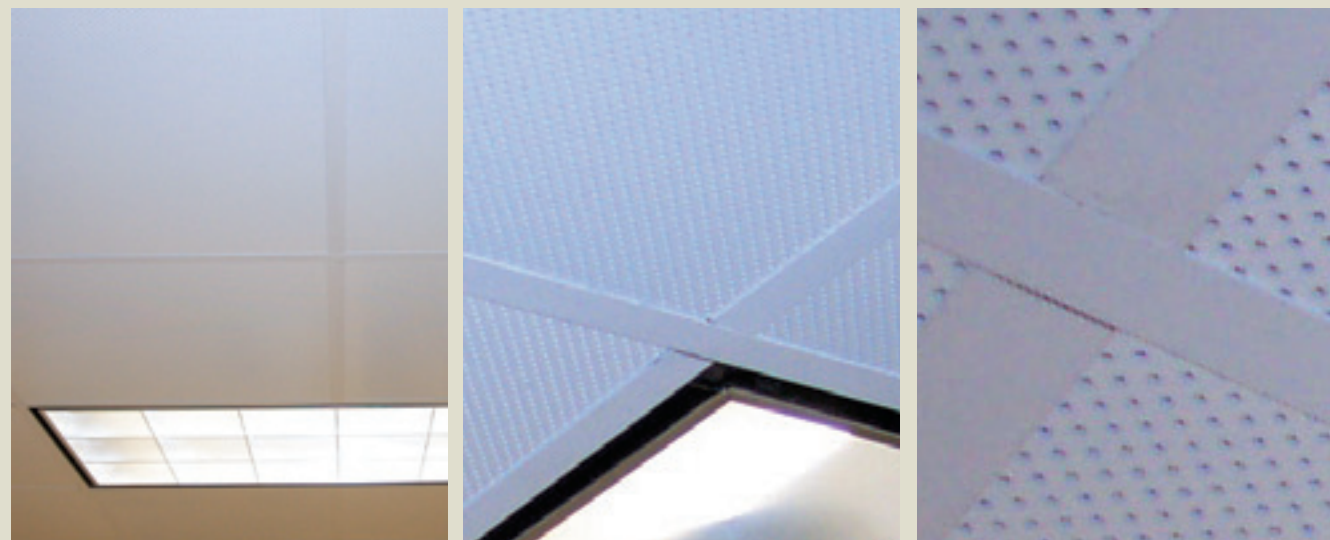

SecureDek® is an acoustical ceiling system **for supervised areas of minimum security corrections facilities.** The system is constructed of standard 2' x 2' or 2' x 4' metal pans with a heavy-duty exposed grid. SecureDek® is also available in aluminum and stainless steel for high-moisture, sanitary areas.

BarrierDek®
Single Skin
Metal Plank
Ceiling

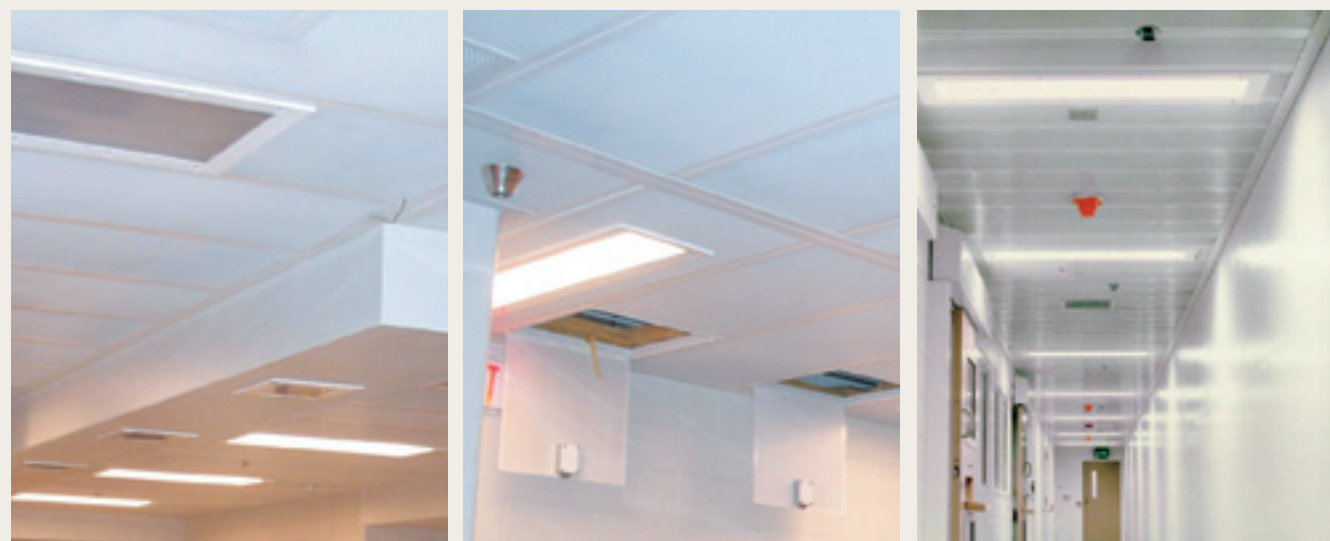

BarrierDek® provides a physical security barrier combined with excellent noise reduction **for medium security areas that are not directly supervised.** When specifying BarrierDek for inmate cells use prime painted 12 gauge non-perforated panels and a welded installation. The construction consists of 12", 18" or 24" wide by 8', 10' and 12' long single layer metal planks supported by perimeter and "T" angles. BarrierDek®, like SecureDek®, is also available in aluminum and stainless steel.

TrussDek®
Double Skin
Metal Plank
Ceiling



TrussDek®, for maximum security areas, is the most secure ceiling system available today. It is designed **for the most demanding security requirements.** Able to withstand attack from the most violent offenders, it is used in inmate cells and segregation units. The construction consists of 24" or 44" wide double layer metal planks with TrussCore® center. The system is supported by perimeter and "T" angles. TrussDek® integrates with Trussbilt's TrussWall® system inside the cell.

Trussbilt **SecureDek®** Metal Pan Ceiling System

The **SecureDek®** metal pan ceiling system is a low-maintenance security acoustical ceiling system composed of 16 gauge galvanized perforated steel panels, 2' x 2' or 2' x 4'. Its panels securely snap into a heavy-duty steel grid with vertical steel compression struts, cutting installation time. Panels are filled with a poly-wrapped fiberglass acoustical blanket to provide high sound absorption values. And, Trussbilt manufactures all access panels for seamless integration with all trades.

SecureDek® Metal Pan Ceiling Systems offer:

Security

- Tamper-proof assembly
- 16 gauge panels
- All steel components

Acoustical Properties

- NRC (Noise Reduction Coefficient) up to .85
- Poly-wrapped fiberglass acoustical blankets

Quality Finish

- White TGIC polyester powder coat finish
- Durability and cleanability
- Superior light reflectivity

Versatility

- Perforated and non-perforated panels
- Stainless steel and aluminum also available for high-moisture and sanitary areas

Options

- Access panels
- Special finish colors

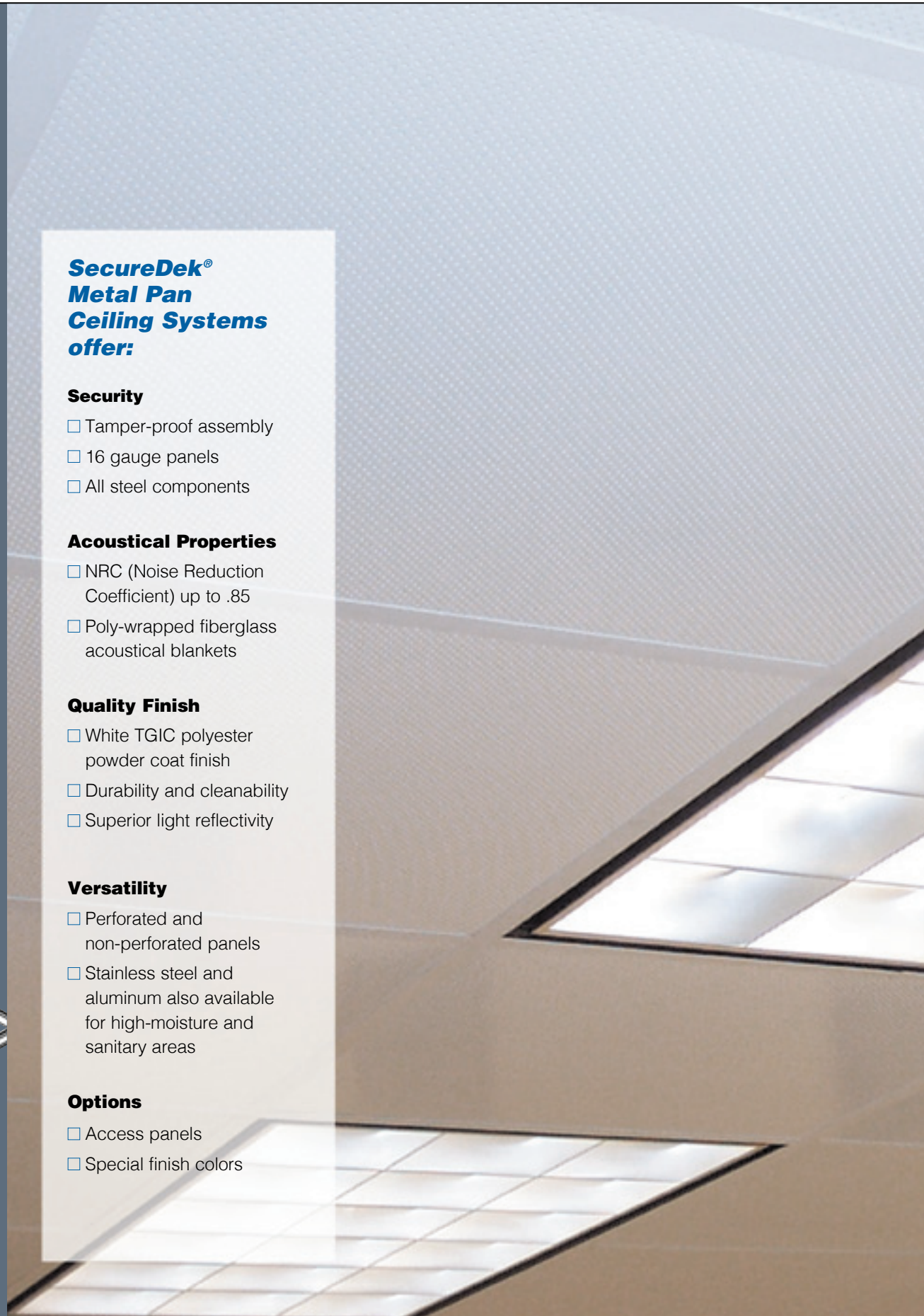
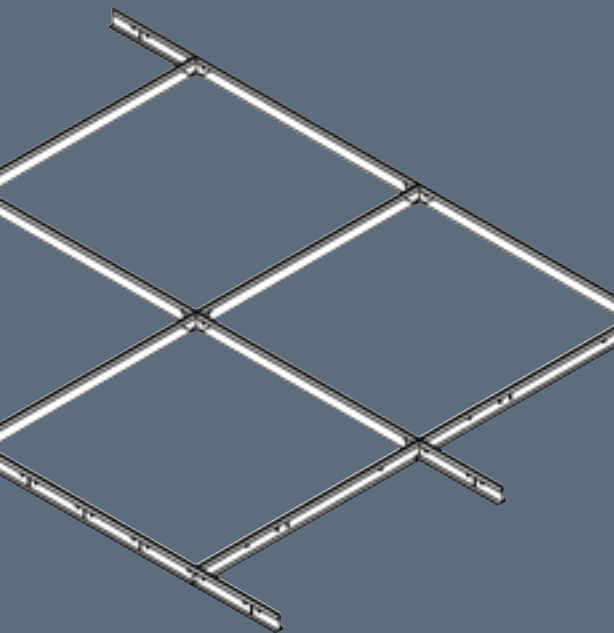

“We chose Trussbilt because of their many years in the business and the high quality of their product. Their experience was an invaluable asset to our design team, as they customized their system to suit our client’s needs and provided a high quality detention system at a great price. The quick erection time and perfect fit of the components helped us to complete the project ahead of schedule.”

Scott Gellner, Project Manager, and Glyn Slattery, Senior Project Manager, Lydig Construction

“I have over 15 years of experience with Trussbilt working on my projects throughout the country. I cannot remember a single time where Trussbilt failed to deliver its products on time. Nor can I remember a case where Trussbilt appeared the least bit reluctant to correct a minor deficiency. In fact, I have found Trussbilt very cooperative and willing to be a partner and part of the solution for the many challenges facing designing and building our nation’s jails and prisons.”

Bill Prindle, LEED A.P., Senior Vice President, HOK

SecureDek® Attaching to Existing Wall

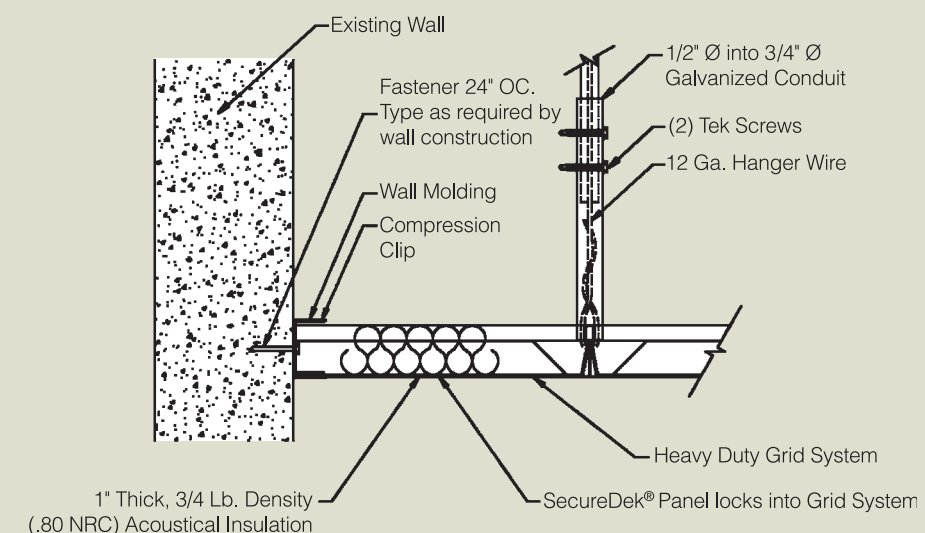

SecureDek® Ceiling System Structure

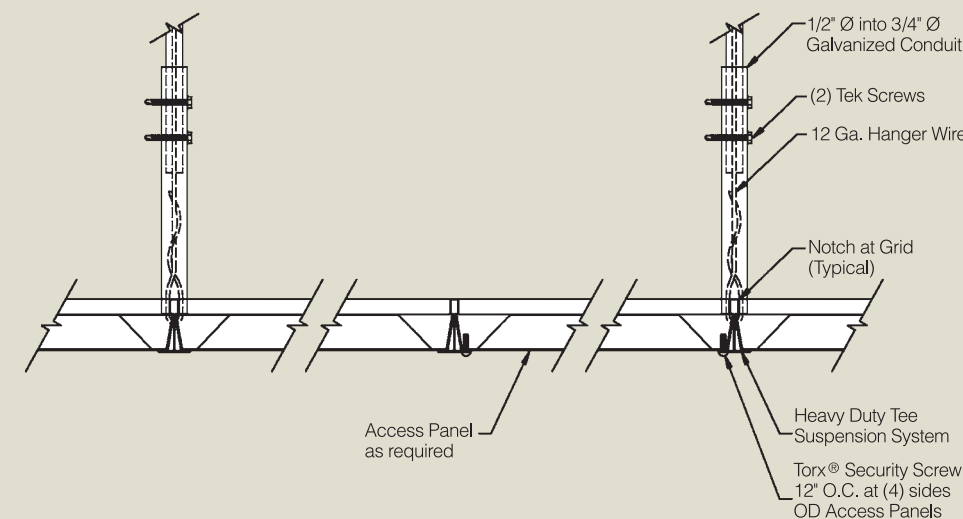

Trussbilt BarrierDek® Metal Plank Ceiling System

The **BarrierDek®** metal plank ceiling system provides an effective security barrier combined with excellent acoustics. The interlocking, single layer panels provide great resistance to passage or attack in applications such as:

- Lobbies and corridors
- Detention dayroom ceilings
- Holding areas
- Visitation areas
- Inmate cells – specify 12 gauge
- Hospital secure areas
- Museums
- Pharmacies
- Gymnasiums and high noise areas
- Burglar-vulnerable areas

The factory finished, powder coated panels are constructed of (A60) galvanized steel and are strong, attractive and moisture resistant. The panels slip into place and are interlocked together, supported by perimeter and “T” angles. No supplemental screw fastening is required, speeding installation time. The interlocking design, TrussLok, physically links the panels together in a formed shape, precluding passage of objects. Trussbilt manufactures all access panels to ensure seamless integration with other trades.

BarrierDek® can be used with Trussbilt’s TrussWall® product for an integrated, single source system, cutting costs at construction and over the life of the facility.

The BarrierDek® Metal Plank Ceiling Systems offer:

Security

- Interlocking design
- Tamper-proof assembly
- 16 gauge is standard for non-inmate cell areas
- 12 gauge for inmate cells, weld-in application
- All steel components

Noise Reduction

- NRC (Noise Reduction Coefficient) up to 1.00 (0.90 standard)
- Poly-wrapped fiberglass blankets

Quality Finish

- White T.G.I.C. polyester powder coat finish
- Durability and cleanability
- Superior light reflectivity

Versatility

- Perforated and non-perforated panels
- Stainless steel or aluminum available
- Widths of 12”, 18” and 24”
- Lengths of 8’, 10’ and 12’

Options

- Medium security screw-type access panels
- Medium and maximum security access panels with lock
- Backer panels
- Special finish colors
- “C” style panels
- Soffits
- Panels cut to length
- Factory cut-outs
- Light fixture mountings



“BarrierDek®’s interlock system provides a secure ceiling with ease of installation, saving valuable time at the site.”

George Mitchell, Owner, Mitchell Construction

“I have been fortunate to work with Trussbilt on a number of successful projects in the corrections industry over the past decade. Trussbilt has proven to be a company that performs at the highest level by delivering a quality product in a very demanding industry.”

F. Wally Riffle, Architect, R & N Systems Design, LLC

BarrierDek® Plank Ceiling System Structure

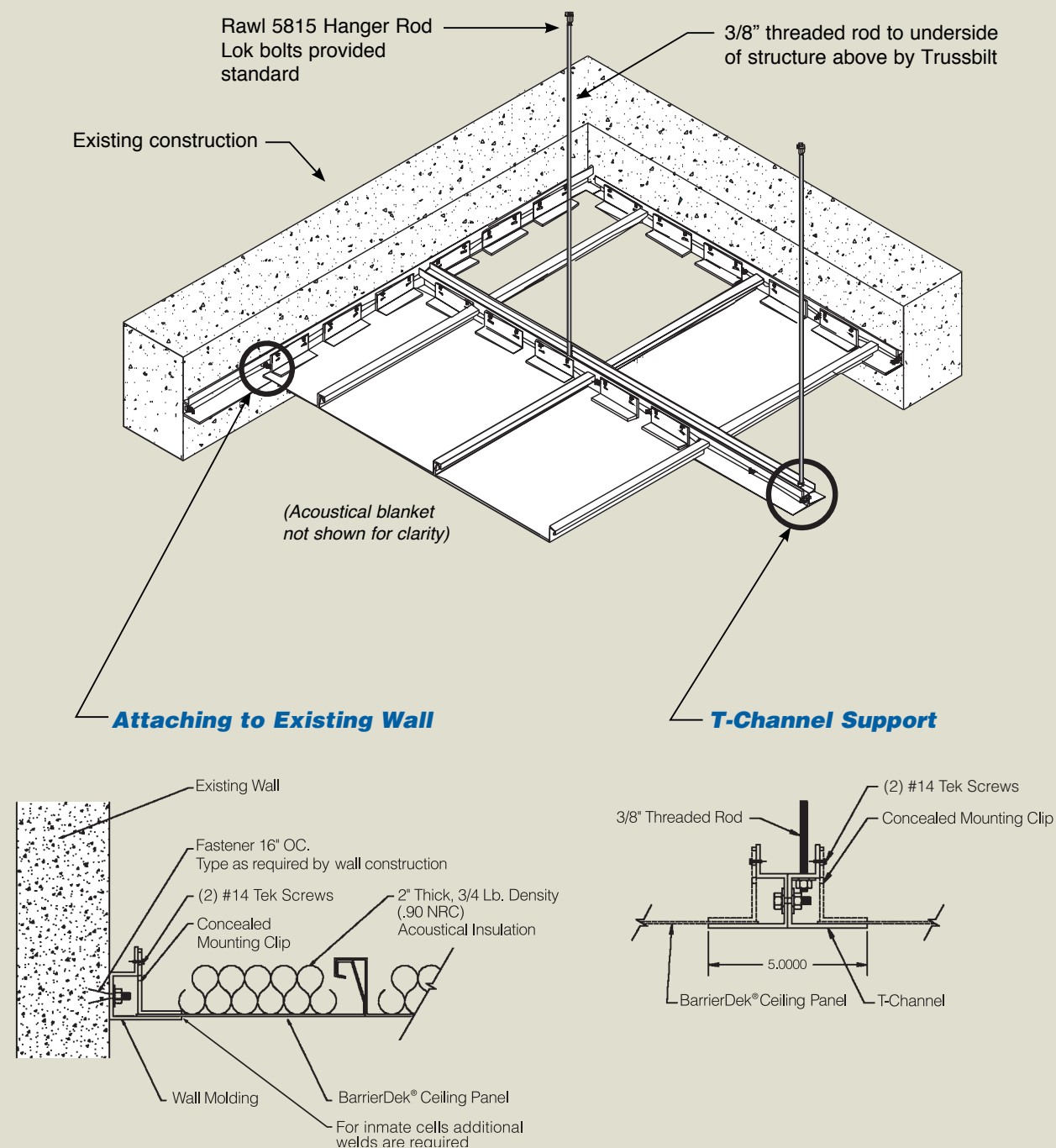

Trussbilt TrussDek® Metal Plank Ceiling System

TrussDek®, a metal plank ceiling system that provides a maximum security barrier combined with excellent acoustics, is the most secure ceiling system available today. Double layer panels combined with a TrussCore® center provide superior resistance to passage or attack in applications such as:

- Inmate cells
- Holding areas
- Detention dayroom ceilings
- Security corridors
- Soffit enclosures
- Wall separators
- Acoustical wall panels

The prime-coated panels are the strongest and most secure product on the market. The panels slide into place and are welded together to provide a secure environment. The shiplap design makes installation quick and easy while preventing the concealment of contraband. The all-steel construction allows placement of accessories and utilities where they are needed, eliminating the need to frame around penetrations. They are supported by perimeter and "T" angles.

Trussbilt manufactures all access panels to ensure seamless integration, reduce coordination efforts, and save installation time. And, TrussDek® can be used with Trussbilt's TrussWall® product for an integrated, single source system, cutting costs at the time of construction and over the life of the facility.

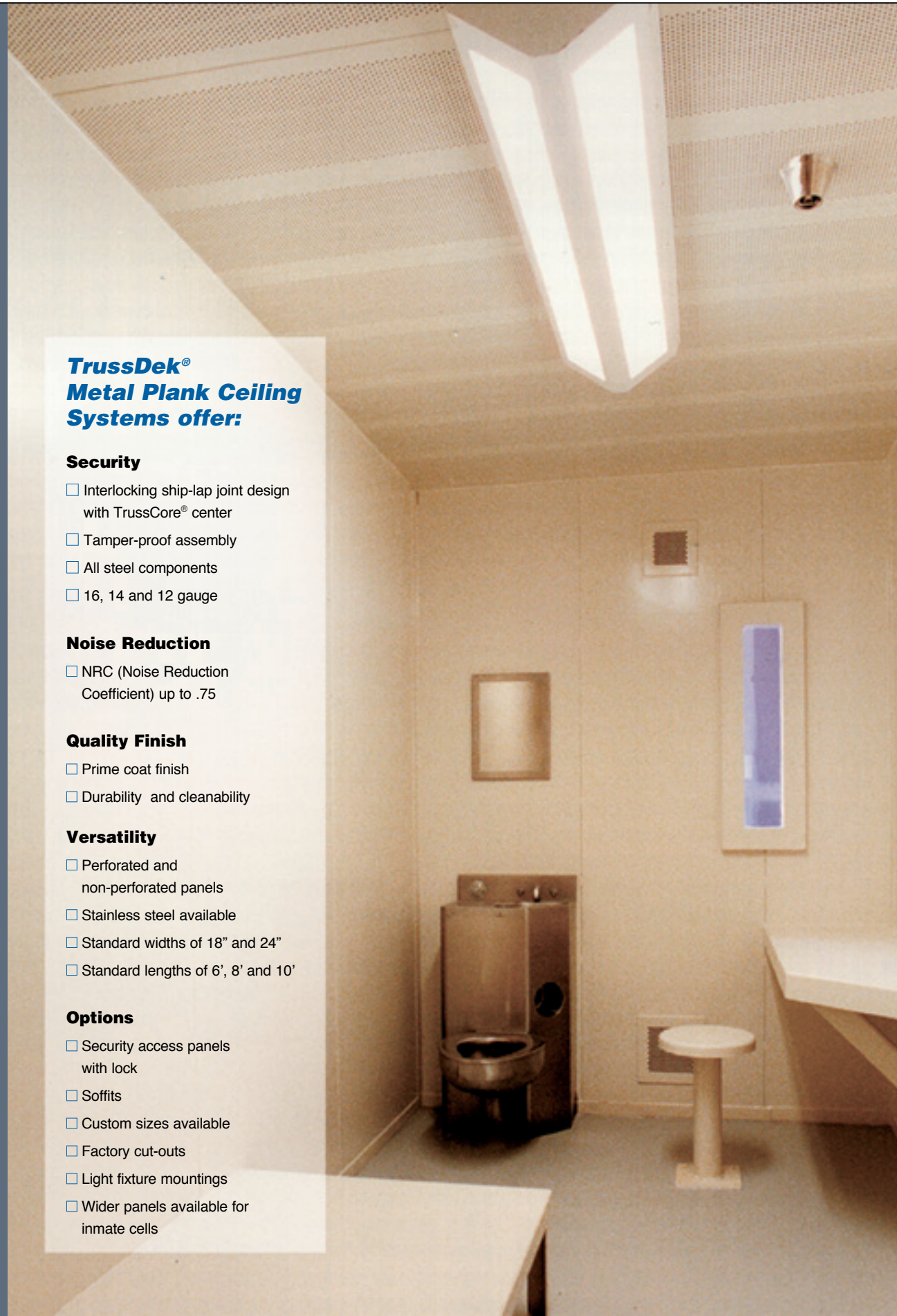

TrussDek® Metal Plank Ceiling Systems offer:

Security

- Interlocking ship-lap joint design with TrussCore® center
- Tamper-proof assembly
- All steel components
- 16, 14 and 12 gauge

Noise Reduction

- NRC (Noise Reduction Coefficient) up to .75

Quality Finish

- Prime coat finish
- Durability and cleanability

Versatility

- Perforated and non-perforated panels
- Stainless steel available
- Standard widths of 18" and 24"
- Standard lengths of 6', 8' and 10'

Options

- Security access panels with lock
- Soffits
- Custom sizes available
- Factory cut-outs
- Light fixture mountings
- Wider panels available for inmate cells

"Trussbilt consistently delivers high quality products at competitive prices, and they deliver them on time. If they make a mistake, they accept responsibility and take immediate action to correct it. I don't think you can ask for more out of a company."

*Randy DeMent, Division Manager
Detention Systems Division, CCC Group Inc.*

"I have been using Trussbilt products in my correctional facility designs for over 25 years. Their product quality is exceptional and among the best in the industry. Trussbilt reliability and integrity make them an exemplar in the detention hollow metal products industry."

Joseph F. Haines, AIA, Senior Principal, DLR Group, Inc.

TrussDek® Plank Ceiling System Structure

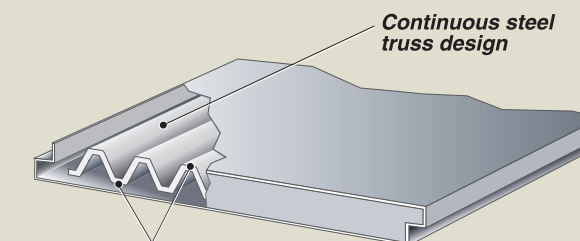

Internally spot welded to both face sheets 3" on center

Attaching to Existing Wall

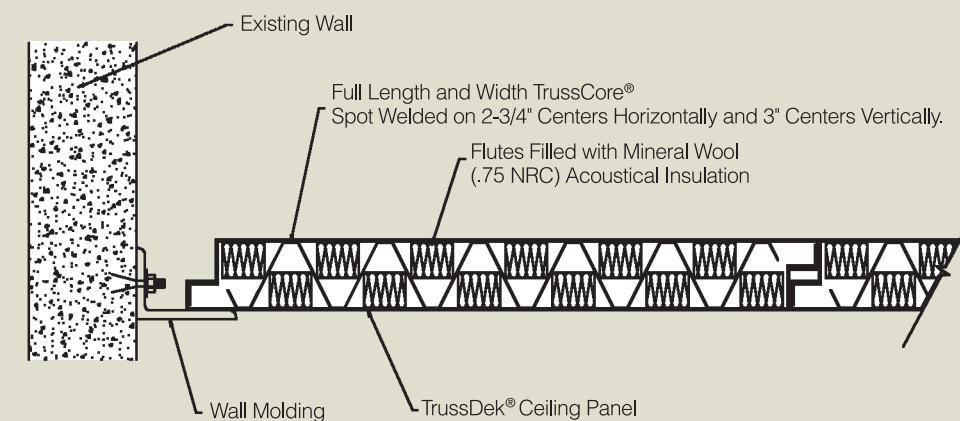

T-Channel Support

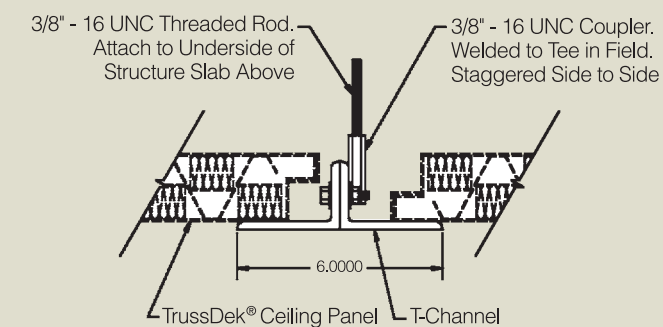

SecureDek® Metal Pan Ceiling



SecureDek® Metal Pan Ceiling

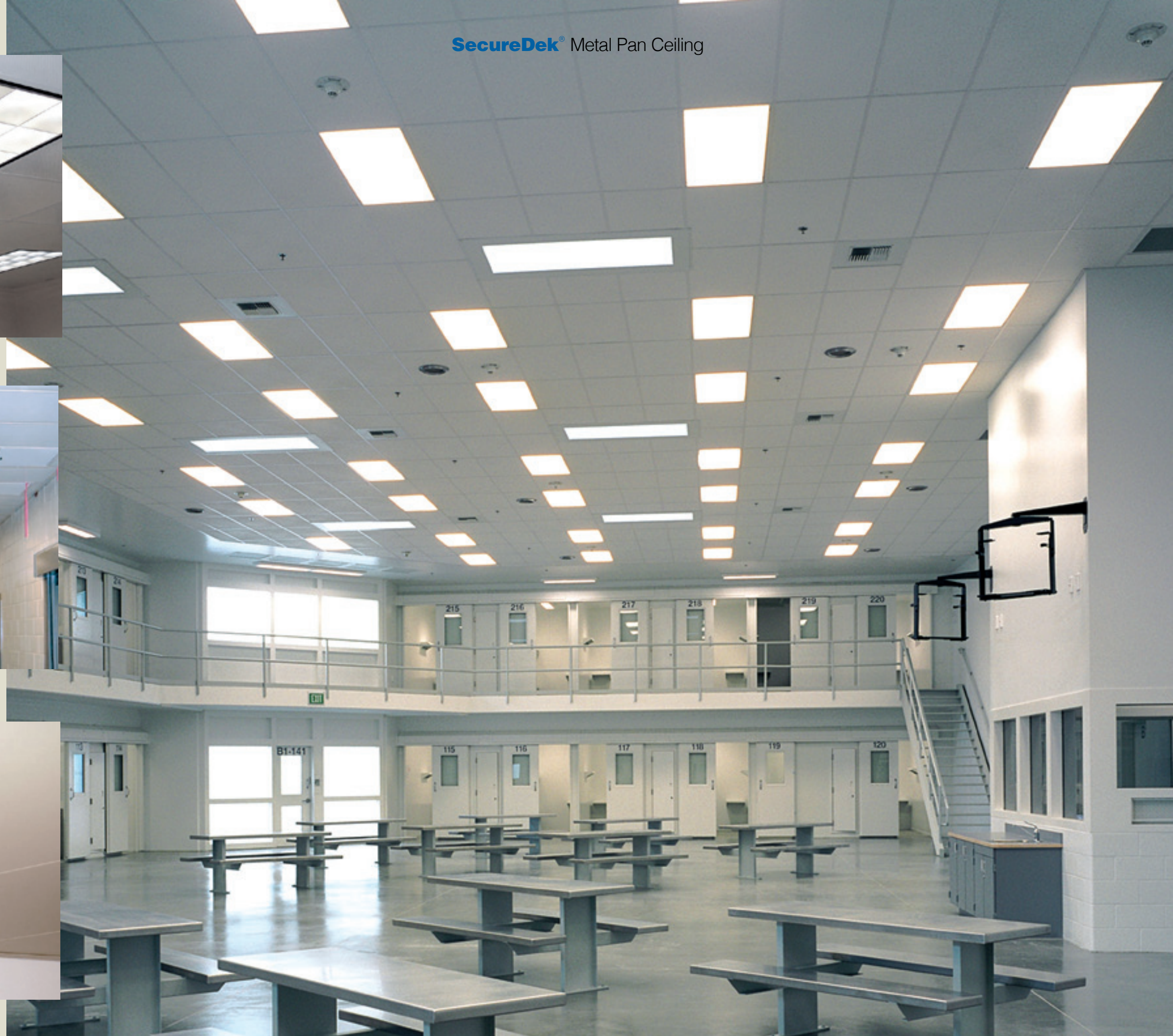

BarrierDek® Single Skin Metal Plank Ceiling



TrussDek® Double Skin Metal Plank Ceiling



Leading Innovator of Security Products for Over 85 Years

Trussbilt has designed and manufactured high quality security products since 1926. Trussbilt's products are used in over 2,000 prisons throughout the world.

- TrussWall® Security Walls
- Security Ceilings
- Detention Doors and Frames
- Safe-T-Feed Food Pass System
- Detention Furnishings

We have developed and pioneered performance tests that demonstrate the superiority of hollow metal fabrication for security. Trussbilt's racking load test, static load test, impact test and edge crush load test have become industry standards.

Our expertise and experience position us as the detention industry's market leader.

ISO 9001:2008 Certified

The product detail and specification information provided herein reflects past experience and is for reference purposes. Trussbilt reserves the right to modify designs and specification requirements. Details will be provided to meet project specification requirements or upon request for specific applications.



Trussbilt

www.trussbilt.com

GENERAL OFFICES

550 Oak Grove Parkway
Vadnais Heights, MN 55127-8509
TEL: 651.633.6100
FAX: 651.633.7100

MANUFACTURING FACILITIES

Main Plant
555 Lincoln Avenue NW
Huron, SD 57350
TEL: 605.352.5283
FAX: 605.352.7141

North Plant/Ceiling Products
801 Lincoln Avenue NW
Huron, SD 57350
TEL: 605.352.7096
FAX: 605.352.7153